

# ***CT800*** TV BRACKET

## INSTALLATION GUIDE

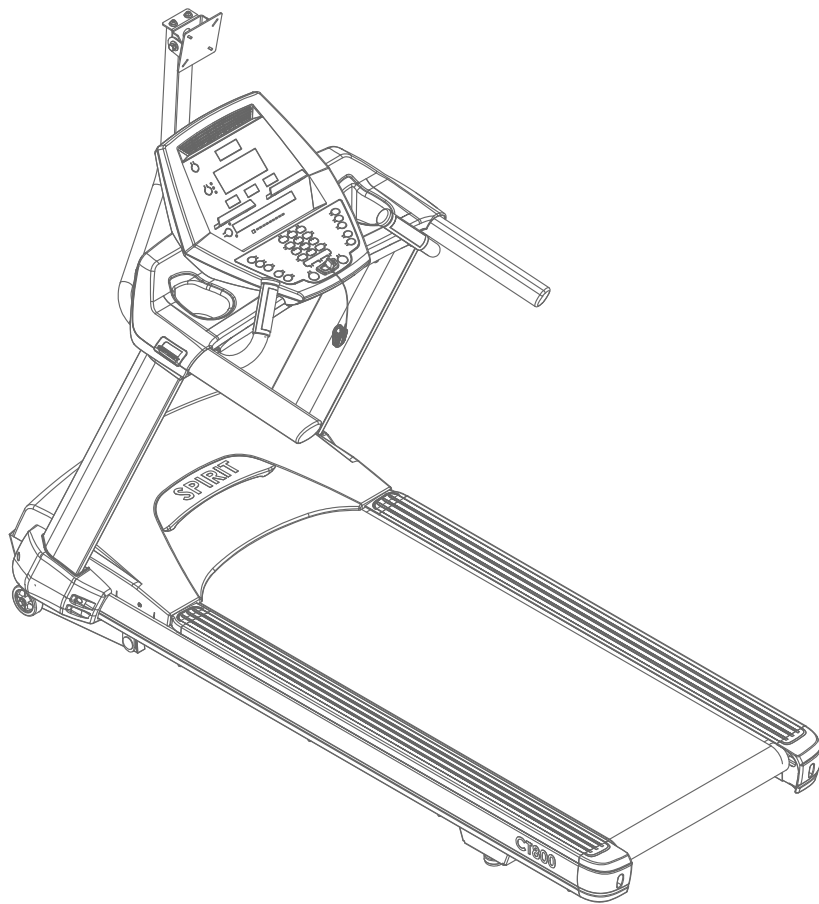



Thank you for your purchase of this TV bracket from Spirit Fitness. This bracket was manufactured by one of the leading fitness manufacturers in the world and is backed by one of the most comprehensive warranties available. Through your dealer, Spirit Fitness will do all we can to make your ownership experience as pleasant as possible for many years to come. If not purchased direct from Spirit Fitness, the local dealership where you purchased this bracket is your administrator for all Spirit Fitness warranty and service needs. Their responsibility is to provide you with the technical knowledge and service personnel to make your experience more informed and any difficulties easier to remedy.

Please take a moment at this time to record the name of the dealer, their telephone number, and the date of purchase below to make any future, needed contact easy. We appreciate your support and we will always remember that you are the reason that we are in business. Please complete and mail your registration card today.

Yours in Health,  
Spirit Fitness

NAME OF DEALER \_\_\_\_\_

DEALER PHONE # \_\_\_\_\_

PURCHASE DATE \_\_\_\_\_

# **CT800 TV BRACKET** STEP ONE

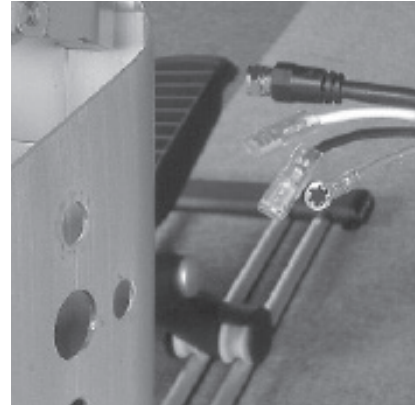

- Insert both coaxial and power cables into the upper hole of the TV bracket tube.
- Leave 12" of the coaxial cable and 4" of the power cable protruding out of the top.
- Guide the two cables through the hole at the bottom of the right-hand TV bracket arm tube.
- All cables go through the hole in the right console mast tube.

# CT800 TV BRACKET STEP TWO

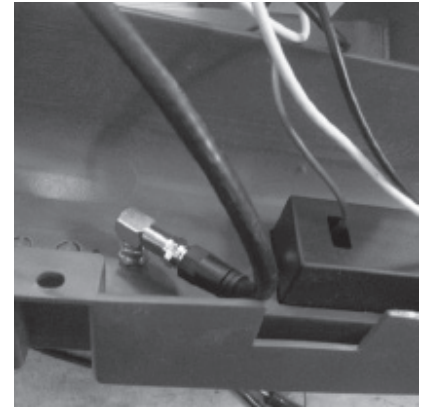
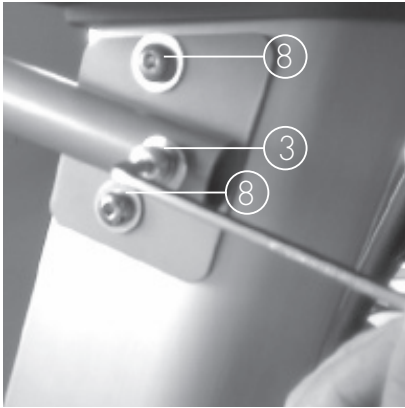

- Attach the round tube onto the upright tube by tightening two **3/8"X1" BOLTS (8)**, two **3/8" SPLIT WASHERS (12)**, two **3/8" FLAT WASHERS (15)**, one **3/8"X2" BOLT (9)** and one **3/8" CURVED WASHER (17)**.
- Wrap around the front side of the right console mast tube and across to the front internal panel below the motor cover.
- Attach the coaxial cable on the front panel.



#8. 3/8" x 1"  
Bolt



#12. 3/8"  
Split Washer



#9. 3/8" x 2"  
Bolt



#15. 3/8"  
Flat Washer



#17. 3/8"  
Curved Washer

# CT800 TV BRACKET STEP THREE



- Exit of coaxial cable.

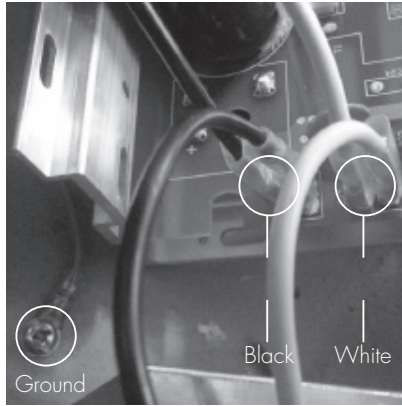

- Attach both black and white power wires on the board next to the corresponding color of the treadmill power wires.
- Screw in the ground wire.



- Attach the **MOUNTING BRACKET (4)** with two **FLAT WASHERS (14)**, two **SPLIT WASHERS (11)**, and two **BUTTON HEAD BOLTS (7)**. Tighten securely with an M5 Allen Wrench.



#7. 5/16" x 15mm  
Bolt



#11. 5/16"  
Split Washer



#14. M8  
Flat Washer

**NOTES**

---



---



---



---



---



---



---



---



---



---



---



---



---



---



---



---



---



---



---



---



---



---



800.258.4555  
spiritservice@spiritfitness.com  
www.spiritfitness.com



Spirit Fitness  
3000 Nestle Road  
Jonesboro, AR 72401



CT800 TV Bracket  
Installation Guide  
© 2017 All Rights Reserved  
Revision: 05.15.2017